

WIRING DIAGRAMS

Article Text

1989 Audi 80

For *** **

Copyright © 1998 Mitchell Repair Information Company, LLC
Wednesday, May 05, 1999 02:30PM

ARTICLE BEGINNING

1989 WIRING DIAGRAMS
Audi Wiring Diagrams

80, 90

COMPONENT LOCATION MENU

COMPONENT LOCATIONS TABLE

AA

| Component | (Figure No.) | Location |
|--|--------------|-----------|
| A/C SYSTEM | (4) | C-E 12-15 |
| ABS SYSTEM | (3) | A-E 8-11 |
| ALTERNATOR | (1) | A 3 |
| AUXILIARY RELAY PANEL LAYOUT | (6) | E 22 |
| BACK-UP LT SW (M/T) | (4) | B 14 |
| BATTERY | (1) | A 1 |
| BLOWER SW | (4) | E 13 |
| CENTRAL LOCKS | (8) | E 29-30 |
| CIG LTRS | (8) | B-D 28 |
| COMBINATION SW | (5) | A 17 |
| COOLANT TEMP SW | (7) | A 24 |
| CRUISE CONTROL | (9) | A-C 32 |
| DEFOGGER SW | (9) | E 33 |
| DIFFERENTIAL LOCKS | (9) | A-B 35 |
| DISTRIBUTOR | (1,2) | E 3, E 5 |
| DOOR LOCK HEATER | (9) | C 32 |
| DOOR SWS | (8) | C-D 29 |
| ELECTRONIC THERMO SW | (7) | B 25 |
| ENGINE COMPT LT | (1) | E 1 |
| FOG LT SWS | (5) | E 16-17 |
| FRONT FOG LTS | (1) | B 1, D 1 |
| FRONT LT CONTROL UNIT | (1) | C 1 |
| FUEL GAUGE SENDER | (5) | E 17 |
| FUEL INJ CONTROL UNIT (90 & 80/90 QUATTRO) | (2) | D 4 |
| FUEL PUMP | (4) | B 15 |
| FUSE #25 | (4) | B 13 |
| FUSE #27 | (6) | B 22 |
| FUSE #28 | (6) | B 22 |
| FUSE/RELAY PANEL | (4,5,6) | C 12-21 |
| FUSE/RELAY PANEL LAYOUT | (6) | A 22 |
| GAUGES | (8) | A-B 28 |
| GEAR SELECTOR SW (A/T) | (4) | A 14 |
| GEAR SELECTOR WARNING | (4) | A-B 15 |
| GLOVE COMPT LT | (8) | D 30 |
| HAZARD FLASHER | (5) | A 19 |
| HEATED SEATS | (9) | C-E 35 |
| HORN SW | (4) | B 13 |
| IGNITION BOOSTER | (1,2) | E 3, E 7 |
| IGNITION COIL | (1,2) | E 3, E 7 |

WIRING DIAGRAMS

Article Text (p. 2)

1989 Audi 80

For *** **

Copyright © 1998 Mitchell Repair Information Company, LLC
Wednesday, May 05, 1999 02:30PM

| | | |
|--|-------|----------------------|
| IGNITION CONTROL UNIT (90 & 80/90 QUATTRO) | (2) | D 7 |
| IGNITION SW | (4) | A 13 |
| INST CLSTR | (7,8) | A-E 26-27, A-B 30-31 |
| INST PANEL LTS BOOSTER | (8) | E 28 |
| INTERIOR LTS | (8) | D-E 30-31 |
| INTERIOR LTS DELAY CTRL UNIT | (8) | C-D 31 |
| JET SPRAY HEATERS | (1) | E 2 |
| LIGHT SW | (5) | E 18-19 |
| LOW COOLANT SW | (7) | A 24 |
| LUGGAGE COMPT LT | (11) | E 43 |
| MEMORY SEATS | (10) | A-E 36-39 |
| MOTRONIC CONTROL UNIT (80 4 CYL) | (1) | C 3 |
| O2 SENS HEATER | (1,2) | B 3, A 4 |
| OIL PRES CONTROL UNIT | (6) | D 23 |
| PARK/NEUT SHIFT LOCK CONTROL UNIT | (6) | C 23 |
| POWER MIRRORS | (11) | A-B 40-41 |
| POWER WINDOWS | (11) | C-E 40-41 |
| POWER WDW/SUNROOF CTRL UNIT | (11) | E 41 |
| RADIATOR COOL FAN | (4) | D 14 |
| RADIO (PARTIAL) | (9) | D 33 |
| REAR FOG LT | (11) | D 43 |
| REAR LT CONTROL UNIT | (11) | B 43 |
| SEAT BELT WARNING RELAY | (8) | C 31 |
| SPEED SENDER | (7) | D 24 |
| STARTER | (1) | A 3 |
| STOP LT SW | (4) | A 13 |
| SUNROOF | (6) | D-E 20-21 |
| WASHER FLUID LEVEL SW | (5) | A 16 |
| W/SHIELD WIPERS | (5) | A-B 16-17 |
| AA | | |

WIRING DIAGRAMS

WIRING DIAGRAMS

Article Text (p. 3)

1989 Audi 80

For *** ** *

Copyright © 1998 Mitchell Repair Information Company, LLC
Wednesday, May 05, 1999 02:30PM

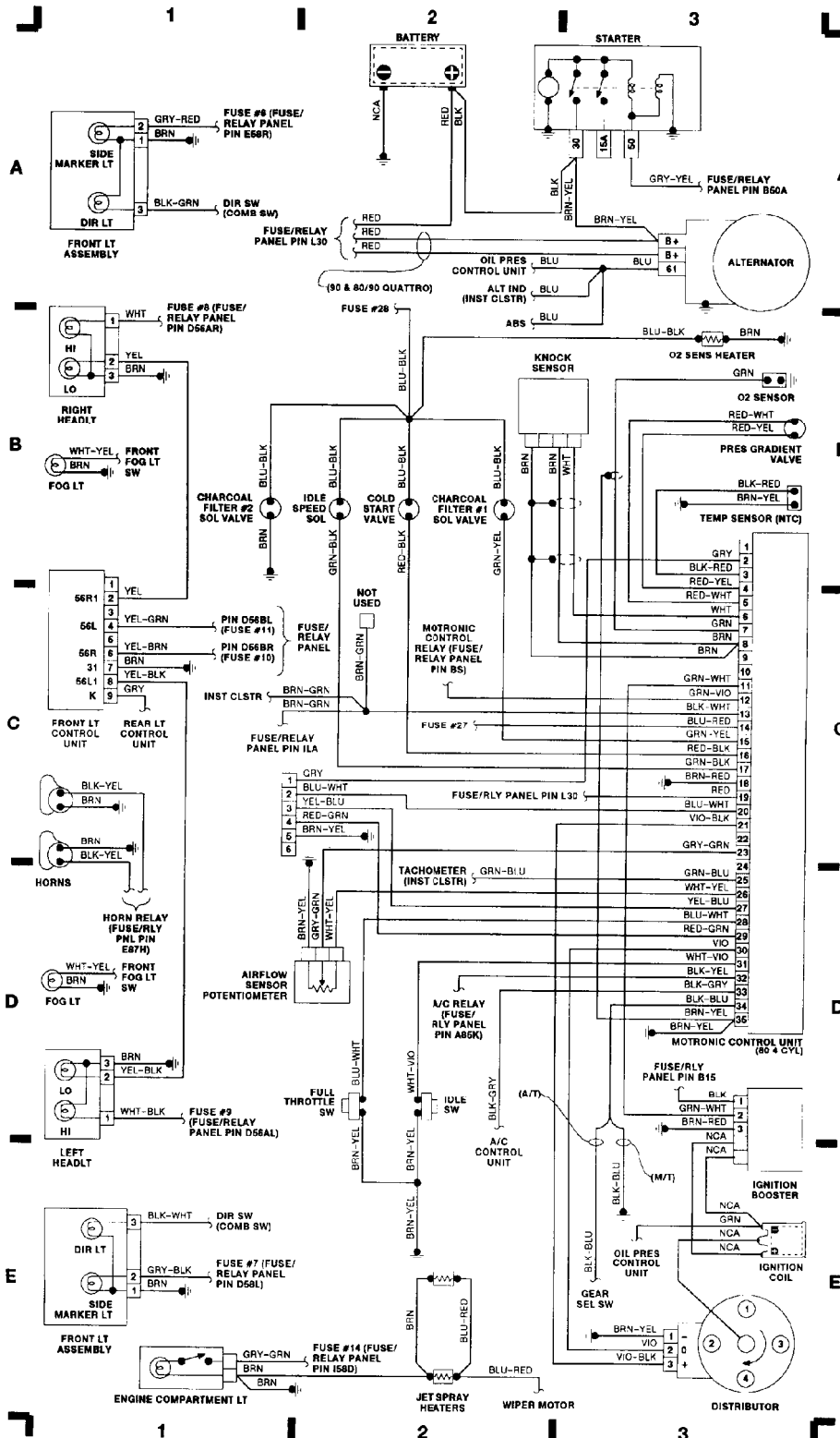

Fig. 1: Engine Compartment & Headlights

90E1126

WIRING DIAGRAMS

Article Text (p. 4)

1989 Audi 80

For *** ** * ** * ** *

Copyright © 1998 Mitchell Repair Information Company, LLC

Wednesday, May 05, 1999 02:30PM

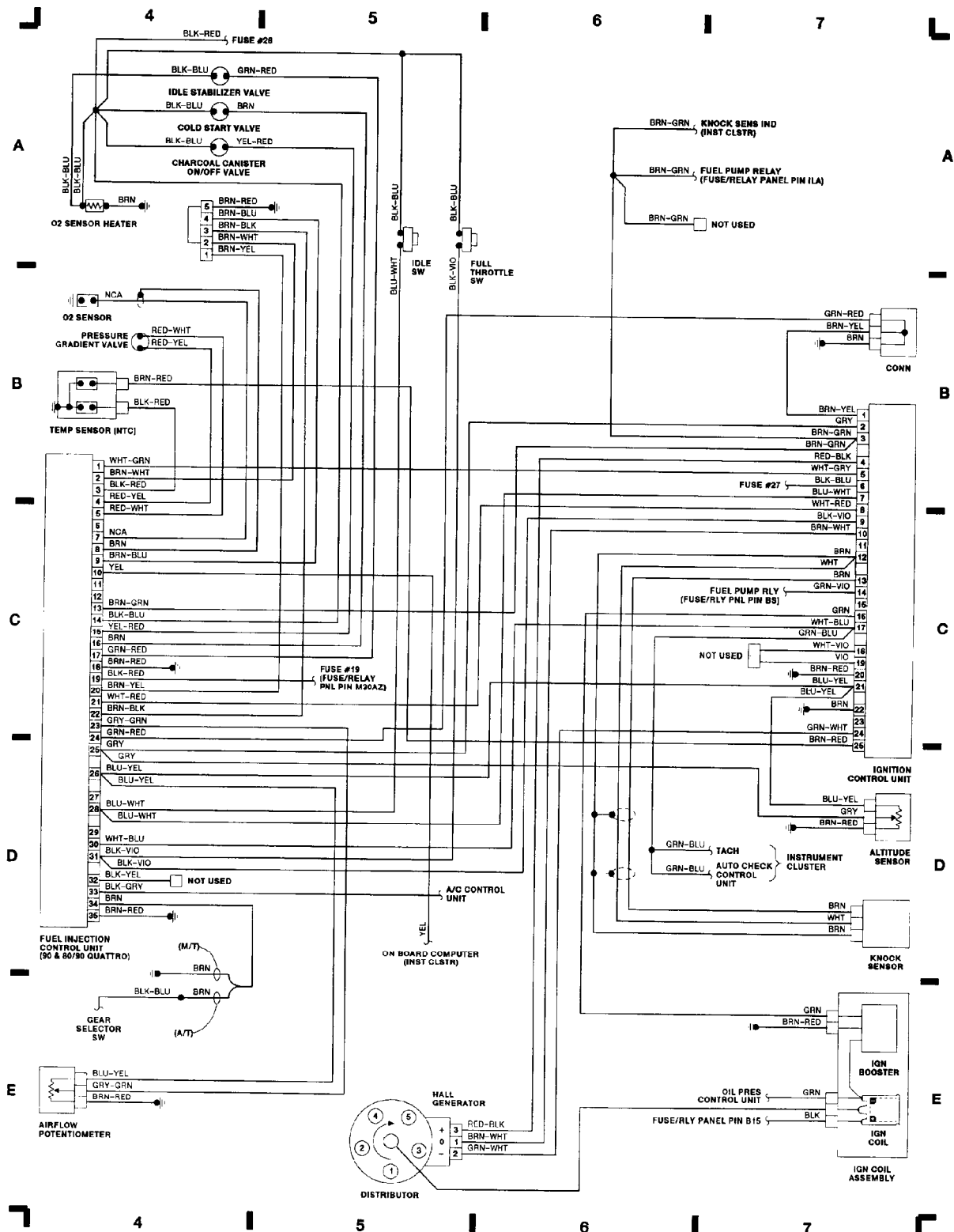

Fig. 2: Computer Engine Control

90F11127

WIRING DIAGRAMS

Article Text (p. 5)

1989 Audi 80

For *** ** * ** * ** *

Copyright © 1998 Mitchell Repair Information Company, LLC
Wednesday, May 05, 1999 02:30PM

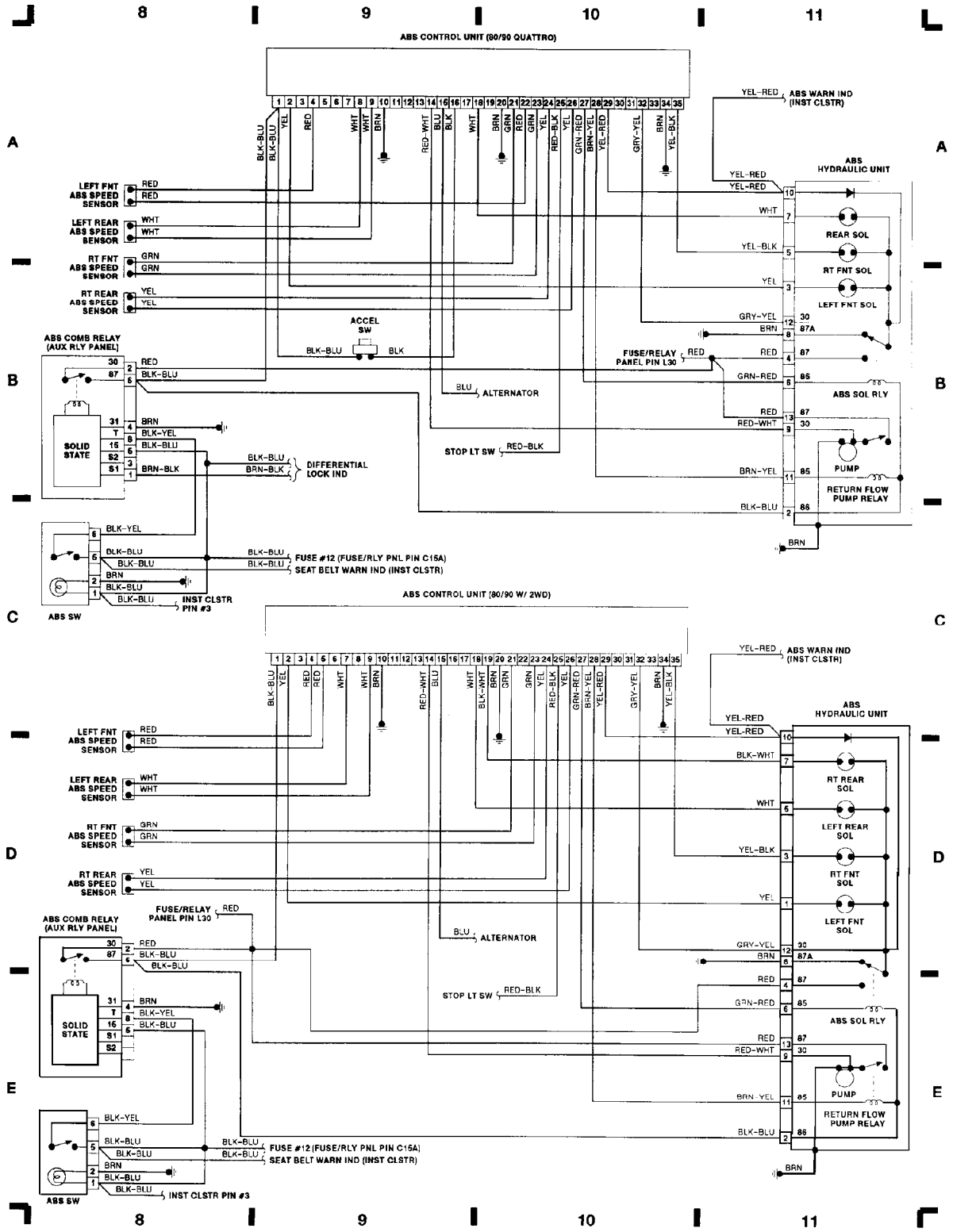

Fig. 3: Anti-Lock Brake System

90G11128

WIRING DIAGRAMS

Article Text (p. 6)

1989 Audi 80

For *****

Copyright © 1998 Mitchell Repair Information Company, LLC
Wednesday, May 05, 1999 02:30PM

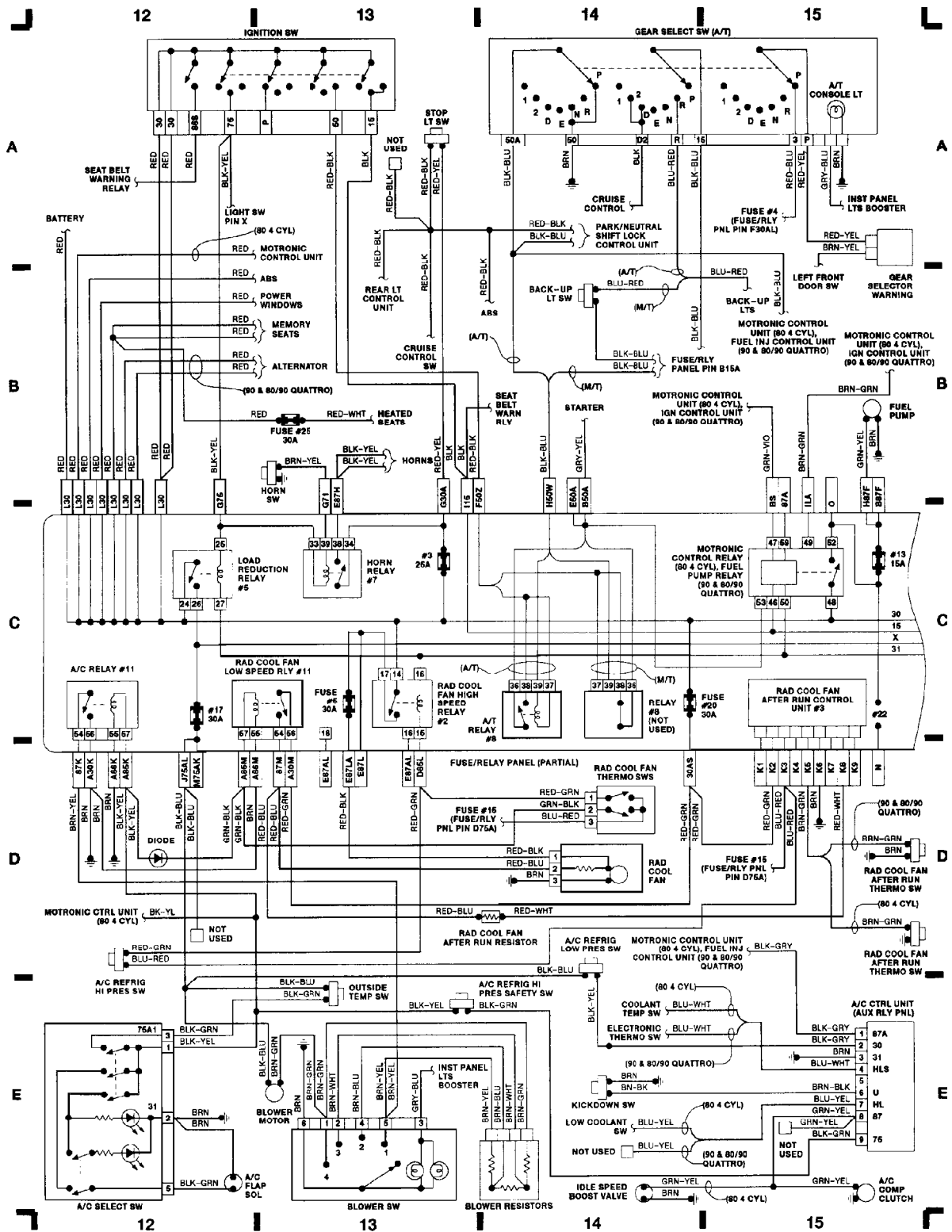

Fig. 4: Fuse Block and A/C & Heating

90H1129

WIRING DIAGRAMS

Article Text (p. 7)

1989 Audi 80

For *****

Copyright © 1998 Mitchell Repair Information Company, LLC
Wednesday, May 05, 1999 02:30PM

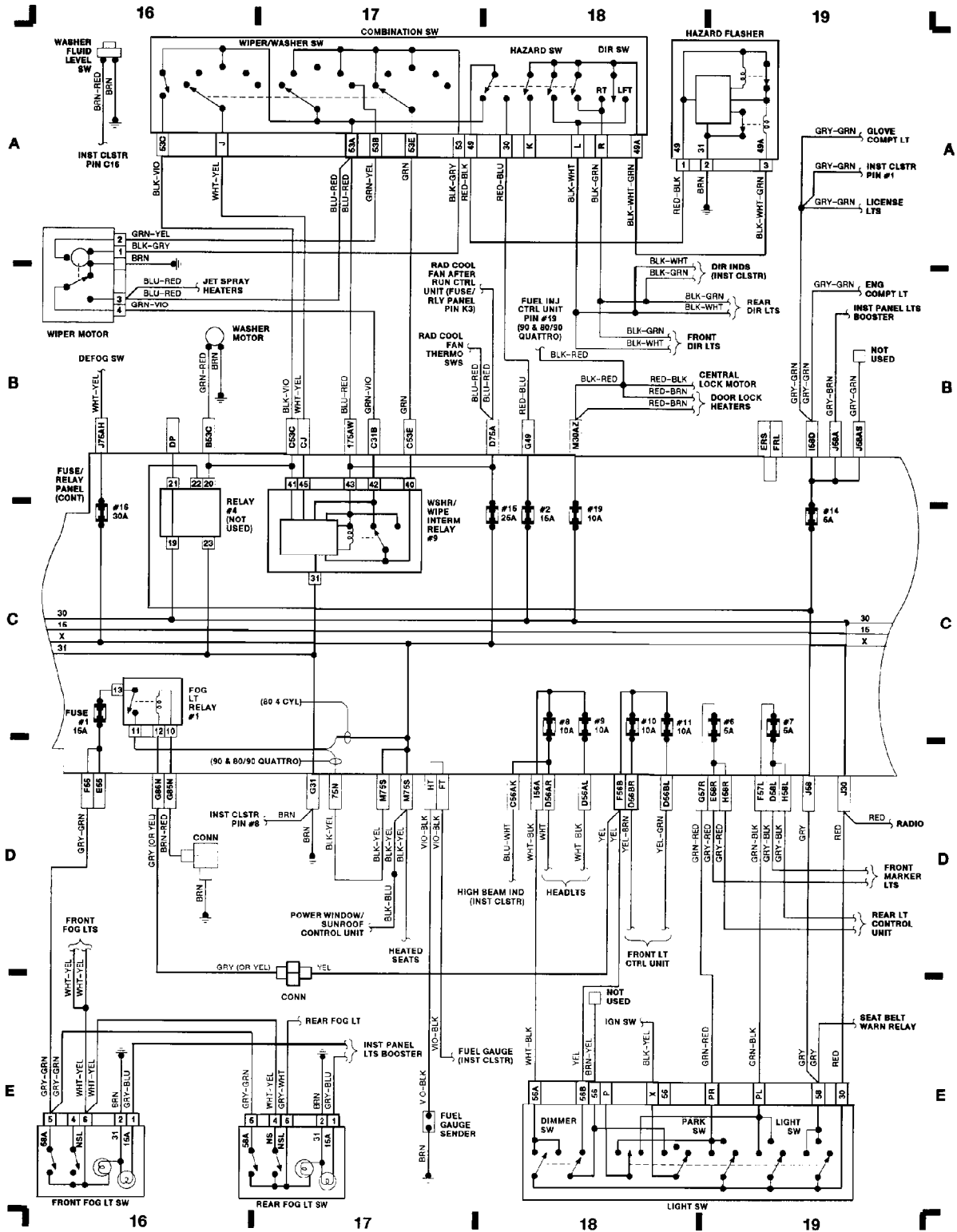

Fig. 5: Fuse Block (Continued) and Combination Switch

90A11130

WIRING DIAGRAMS

Article Text (p. 8)

1989 Audi 80

For *** **

Copyright © 1998 Mitchell Repair Information Company, LLC

Wednesday, May 05, 1999 02:30PM

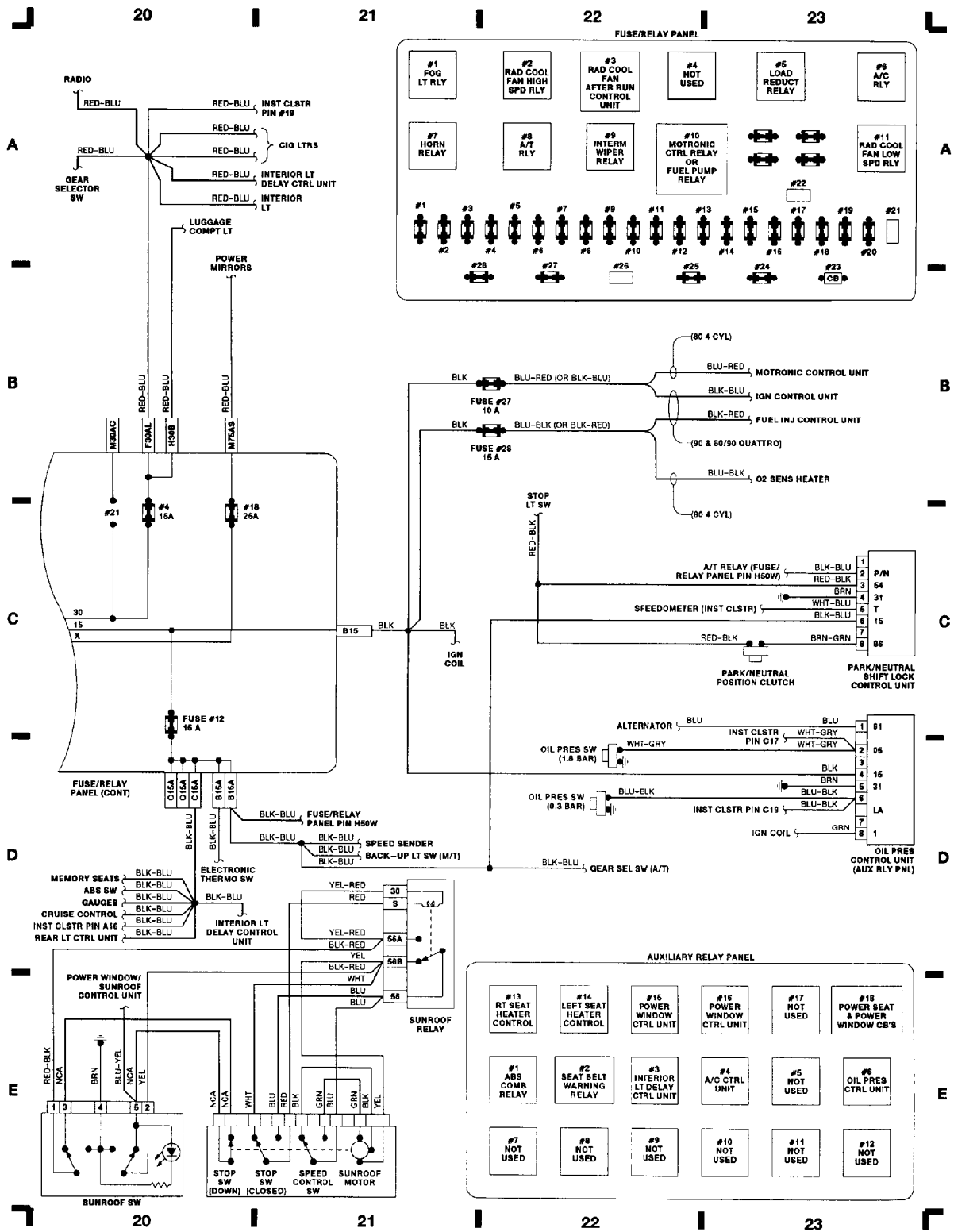

Fig. 6: Fuse/Relay Panel and Auxiliary Relay Panel

90B11131

WIRING DIAGRAMS

Article Text (p. 9)

1989 Audi 80

For *** ** * ** * ** * ** *

Copyright © 1998 Mitchell Repair Information Company, LLC
 Wednesday, May 05, 1999 02:30PM

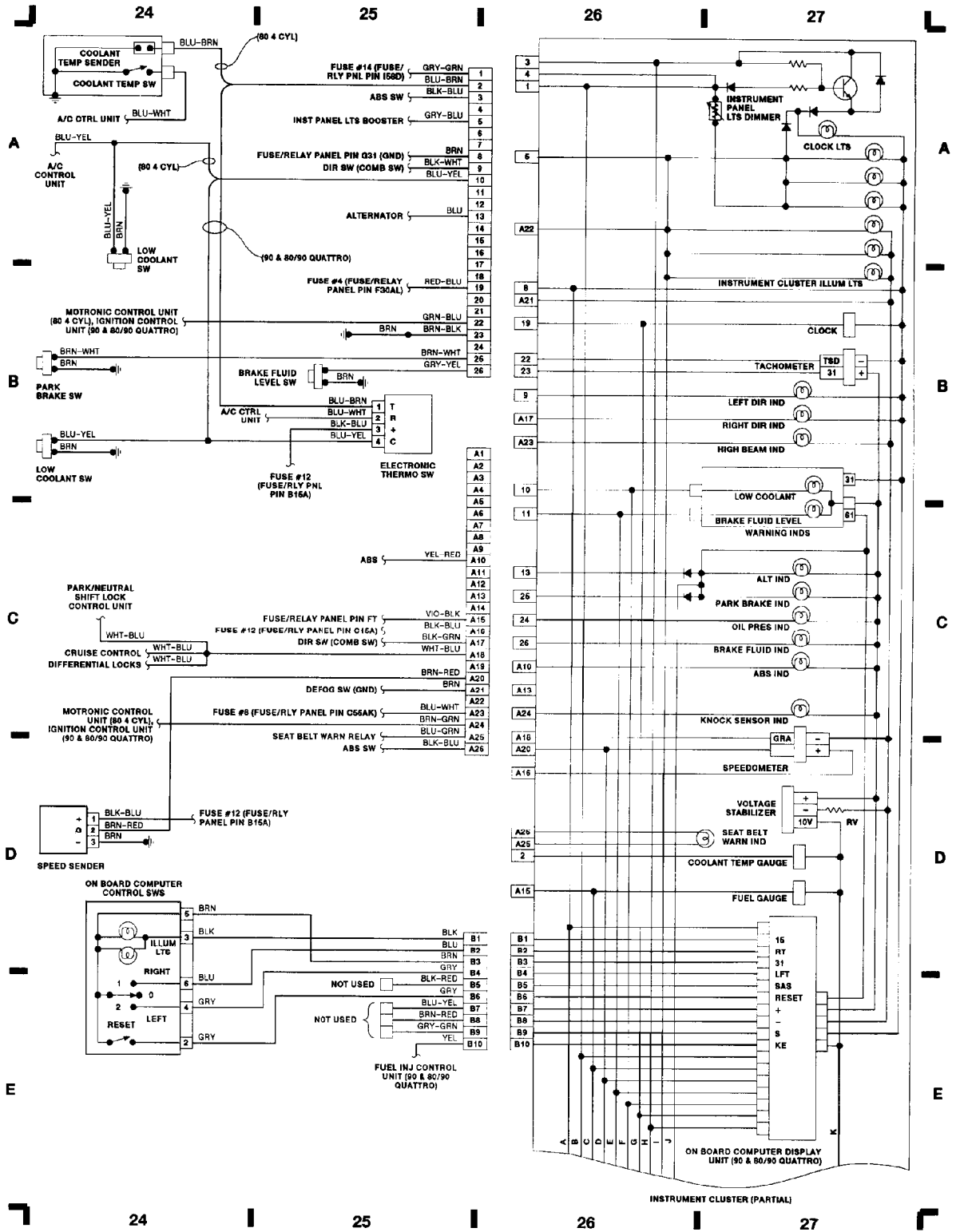

Fig. 7: Instrument Panel

90C11132

WIRING DIAGRAMS

Article Text (p. 10)

1989 Audi 80

For *** ** ** ** **

Copyright © 1998 Mitchell Repair Information Company, LLC
Wednesday, May 05, 1999 02:30PM

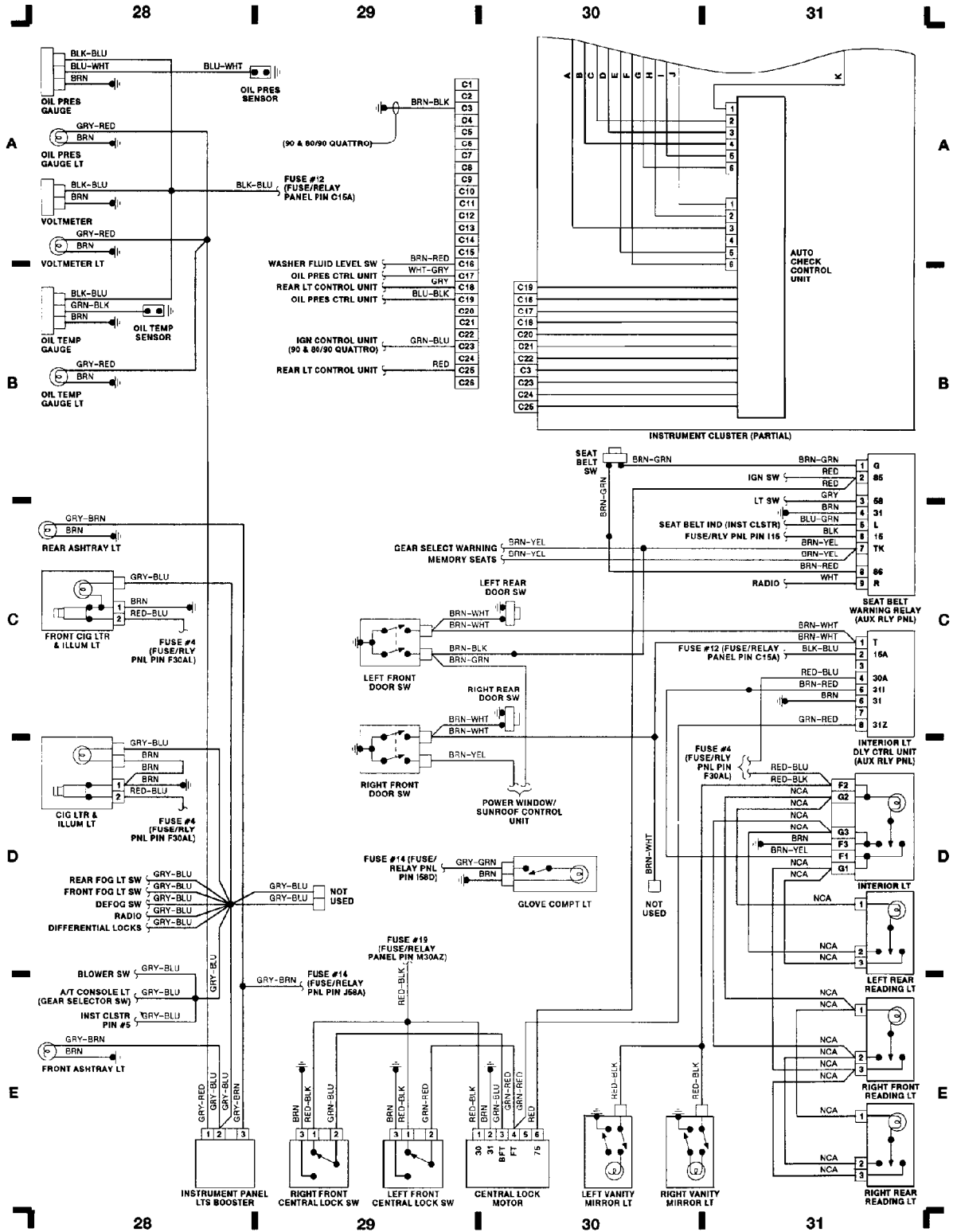

Fig. 8: Instrument Panel (Continued) and Gauges

90D11133

WIRING DIAGRAMS

Article Text (p. 11)

1989 Audi 80

For *** **

Copyright © 1998 Mitchell Repair Information Company, LLC

Wednesday, May 05, 1999 02:30PM

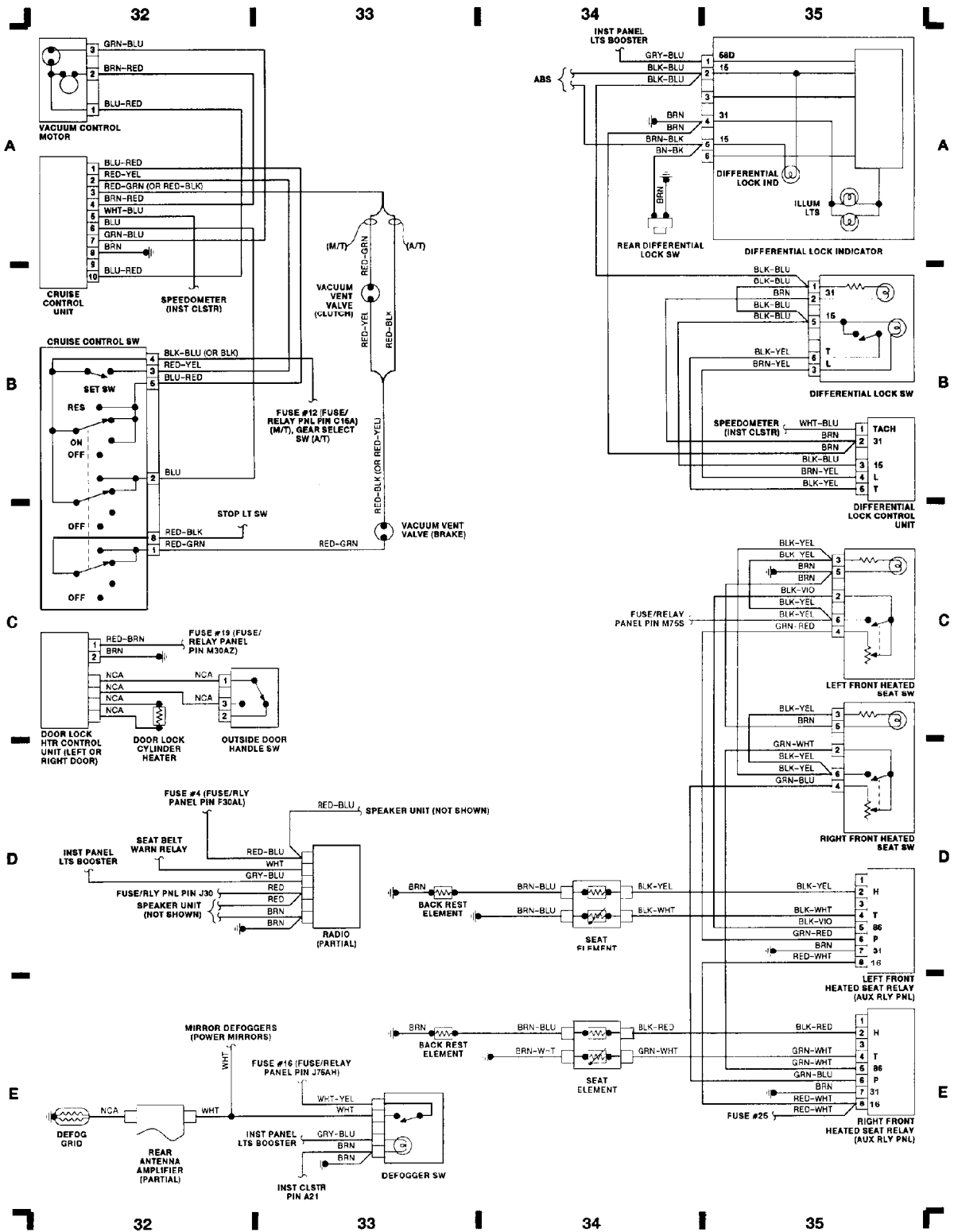

Fig. 9: Cruise Control and Accessories

90E11134

WIRING DIAGRAMS

Article Text (p. 12)

1989 Audi 80

For *** ** * ** * ** * ** *

Copyright © 1998 Mitchell Repair Information Company, LLC
Wednesday, May 05, 1999 02:30PM

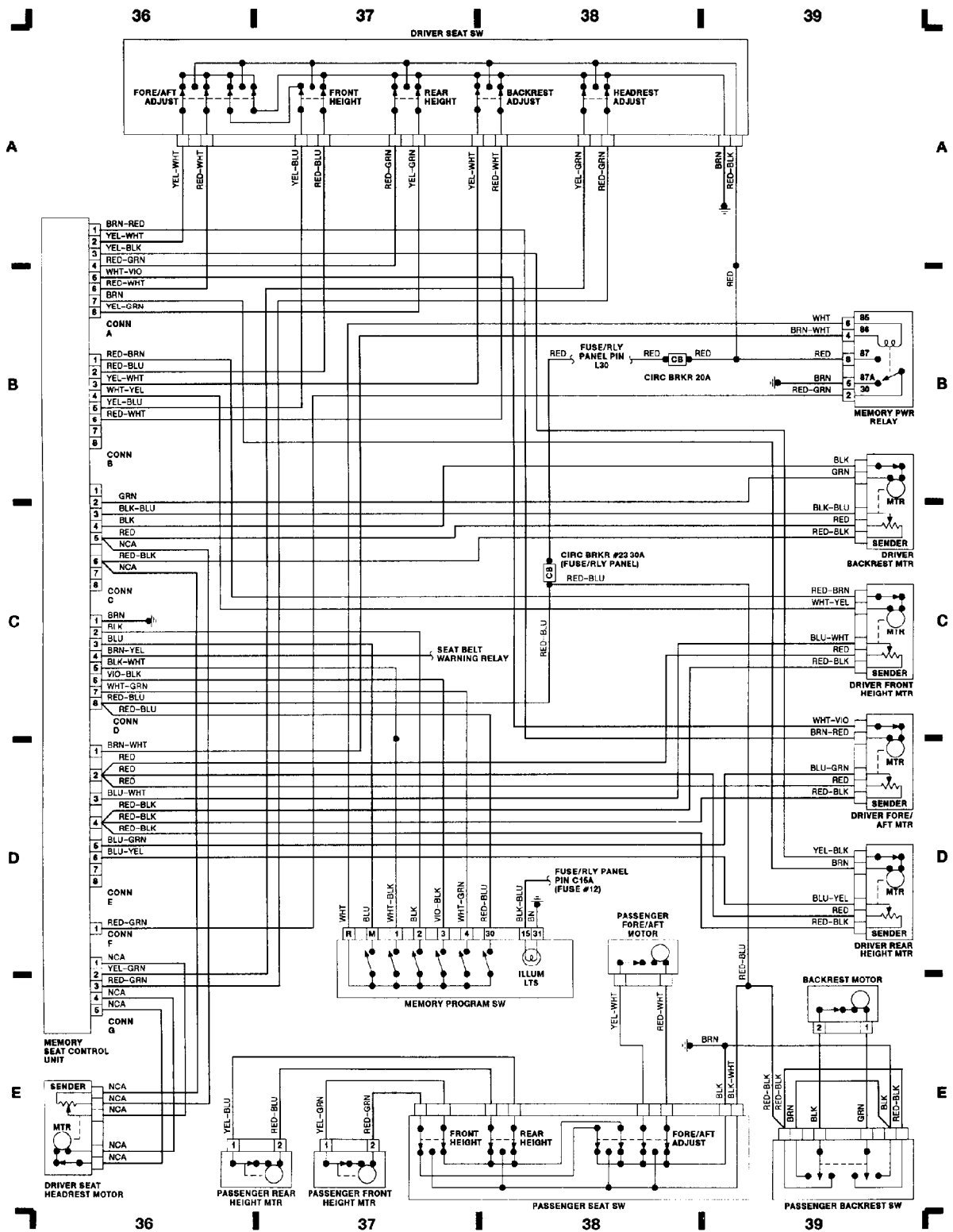

Fig. 10: Power Seat System

90F11135

WIRING DIAGRAMS

Article Text (p. 13)

1989 Audi 80

For *** ** * ** * ** * ** *

Copyright © 1998 Mitchell Repair Information Company, LLC

Wednesday, May 05, 1999 02:30PM

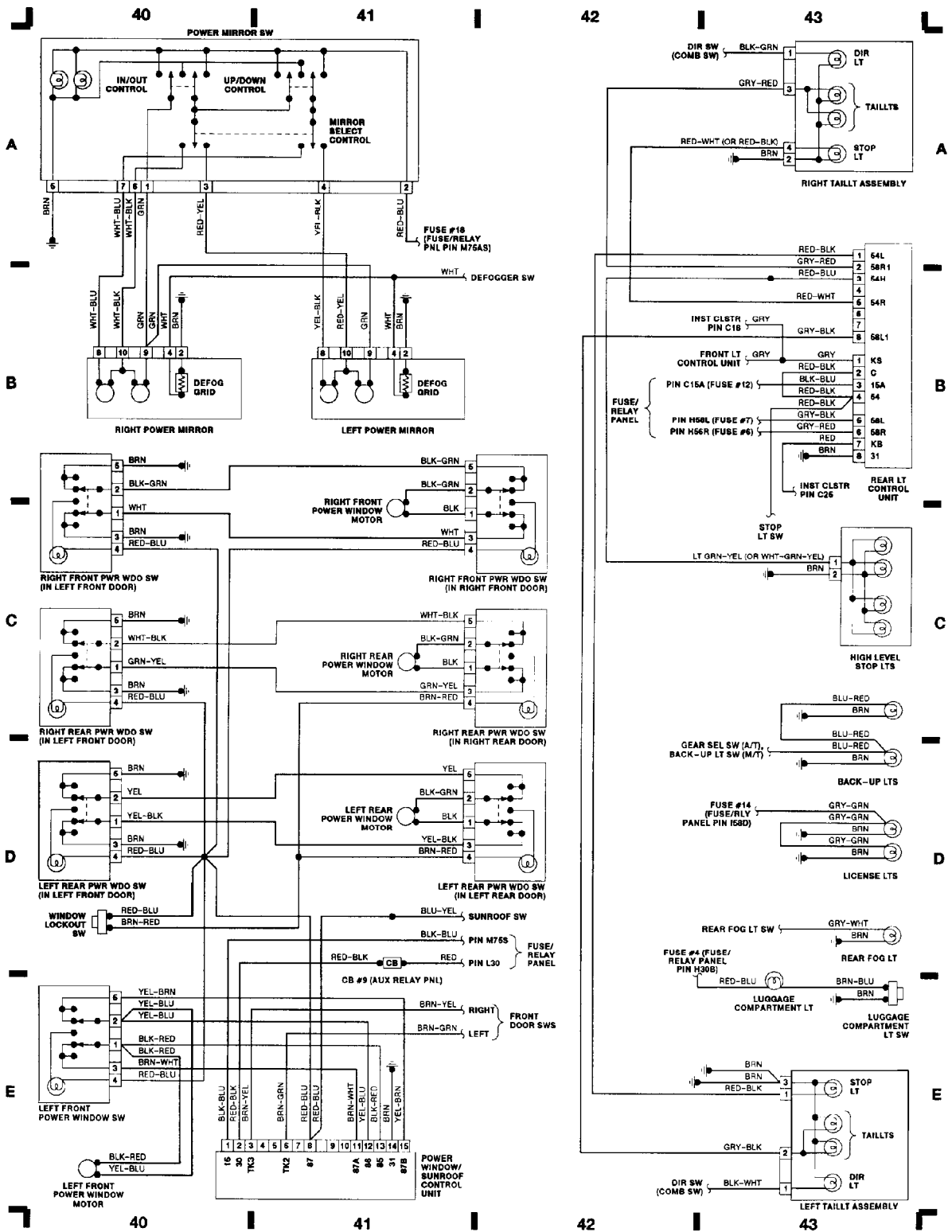

Fig. 11: Passenger Compartment & Taillights

90G11136

END OF ARTICLE